

Chapter 2

Computer Components

A computer is a device that accepts data and processes it for some result based on a sequence of instructions. The sequence of instructions given to computer for manipulating data is known as a **program**. Computers also include the means for storing data and the program on internal memory. The process of performing arithmetic and logic operations with the help of computer is known as **electronic data processing (EDP)**.

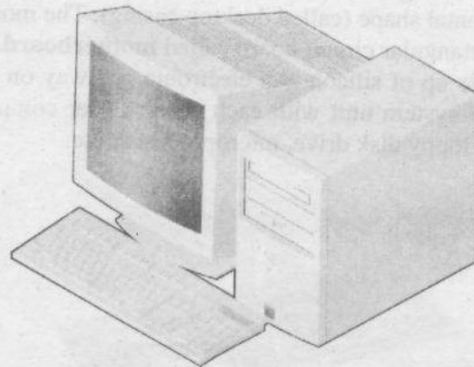

Figure 2.1: A Computer System (PC)

2.1 Components of Computer System

There are two basic components of a computer system.

- Computer Hardware.
- Computer Software.

2.1.1 Computer Hardware

The physical parts of the computer system that you can touch and feel are known as **computer hardware**. In a broader sense a computer can be divided into following hardware units:

- Input Unit
- Output Unit
- System Unit

Chapter 2

Computer Components

A computer is a device that accepts data and processes it for some result based on a sequence of instructions. The sequence of instructions given to computer for manipulating data is known as a **program**. Computers also include the means for storing data and the program on internal memory. The process of performing arithmetic and logic operations with the help of computer is known as **electronic data processing (EDP)**.

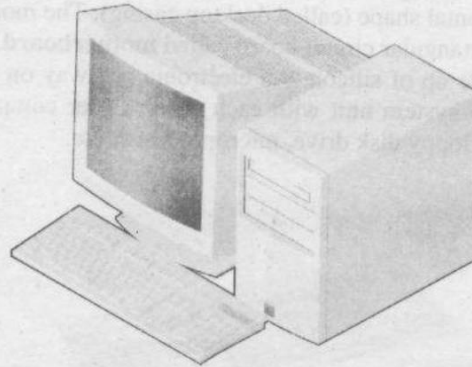

Figure 2.1: A Computer System (PC)

2.1 Components of Computer System

There are two basic components of a computer system.

- Computer Hardware.
- Computer Software.

2.1.1 Computer Hardware

The physical parts of the computer system that you can touch and feel are known as **computer hardware**. In a broader sense a computer can be divided into following hardware units:

- Input Unit
- Output Unit
- System Unit

INPUT UNIT

Input unit of a computer system consists of input devices. Due to the diverse nature of the data, variety of input devices exist to input data in different forms e.g. keyboard is used to enter textual data, mouse is used as a pointing device and to trigger different commands in different applications, microphone is used to enter voice data, and scanner is used to enter image data etc. Input unit of a computer may contain all or some of the above described devices, and even can have many other.

OUTPUT UNIT

Output unit of a computer system consists of output devices. As data presented to the user can take variety of forms, therefore different output devices are needed e.g. monitor is used to display text and images on a screen, printer is used to get output on paper; speaker is used to receive voice output etc.

SYSTEM UNIT

System unit contains a number of other components which are enclosed in a rectangular casing. The casing is available in two different shapes i.e. vertical shape (called tower casing) and horizontal shape (called desktop casing). The most important component of system unit is a rigid rectangular circuit board called **motherboard**. All other components are etched onto it. It is made up of silicon. An electronic pathway on the motherboard connects different components of system unit with each other. Other components of system unit are RAM, hard disk drive, floppy disk drive, microprocessor etc.



(a) Mouse

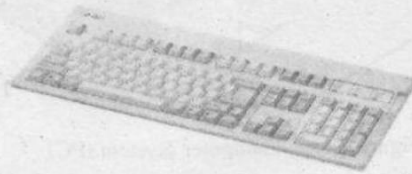

(b) Keyboard



(c) Monitor



(d) System Unit



(e) Printer

Figure 2.2: Computer Hardware Components

2.1.2 Computer Software

Computer Software is a term used for organized collections of computer data and instructions. Computer programs are also usually referred to as computer software. A *Computer Program* is a set of instructions given to the computer to solve a particular problem. Computer programs specify a sequence of operations that the computer will perform.

Computer Software is further divided into two major categories

- System Software
- Application software

SYSTEM SOFTWARE

System Software refers to the programs that are responsible for controlling and managing the actual operations of the computer hardware. Generally system software consists of an operating system and some fundamental utilities such as disk formatters, file managers, display managers, user authentication (login) and network control software.

APPLICATION SOFTWARE

Application Software is used to accomplish tasks specified by the user. Application software may consist of a single program, such as an image viewer or a collection of programs (called *software package*) that work together to accomplish a task. e.g. word processor, spreadsheet, database etc.

2.2 Organization of Computer

A computer performs the following five major functions:

- Accepts data or instructions from input device
- Stores data
- Processes data as required by the user
- Gives results in the form of output
- Controls all operations inside a computer.

In order to perform above mentioned operations; the computer system is divided into three units. These are

- Central processing unit (CPU).
- Memory unit
- Input / Output units

2.2.1 Central Processing Unit (CPU)

The Central Processing Unit (CPU) is generally referred to as the brain of the computer. The primary work of CPU is to convert data from input, process the data

and output in useful information that can be used by either user or other computer programs. Central processing unit (CPU) is a highly complex set of electronic circuitry that executes program instructions. It is like a really fast calculator that has the ability to recall numbers from various locations in memory, perform arithmetic and logical operations with them, such as addition or multiplication, and then store the results.

All computers must have a central processing unit. As Figure 2.3 shows, the central processing unit consists of two main parts: The control unit, arithmetic and logic unit. Each part has a specific function.

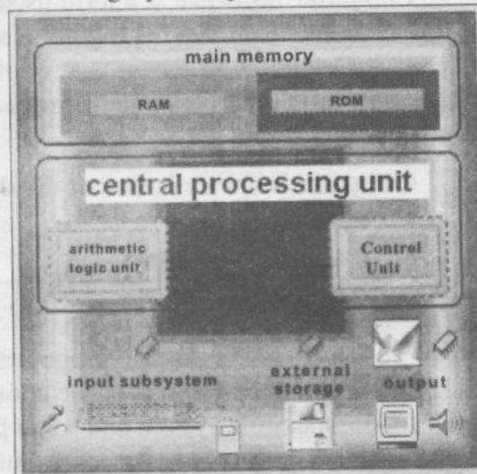

Figure 2.3: Components of Computer System

2.2.2 Arithmetic and Logic Unit (ALU)

The Arithmetic and Logic Unit (ALU) consists of electronic circuitry that executes all arithmetic and logical operations.

The arithmetic and logic unit can perform the following operations, like:

- Addition
- Subtraction
- Multiplication
- Division
- Logical Operations

A logical operation is usually a comparison of numbers, letters, or special characters. The computer can then take action based on the result of the comparison. This is a very important capability. It is by comparing that a computer is able to tell, for example, whether there are available seats on train, whether mobile phone customers have exceeded their pre paid credit limits etc.

Logical operations can test for three conditions:

- **Equal-to condition:** The arithmetic and logic unit compares two values to determine if they are equal. For example, if the number of tickets sold equals the number of seats in the hall, then no more tickets are available.
- **Less-than condition:** The computer compares values to determine if one is less than another. For example, if the hours a person worked this week are less than 35, then some fine is deducted from his salary.

- **Greater-than condition.** The computer determines if one value is greater than another. For example, if the hours a person worked this week are greater than 40, then he gets bonus for working over time.

2.2.3 Control Unit (CU)

The Control Unit consists of circuitry that generates signals to direct the entire computer system to carry out or execute the programs. The control unit itself does not execute program instructions; rather, it directs other parts of the system to do so. The control unit must communicate with the arithmetic and logic unit, memory and other parts of computer system.

It also controls the flow of information through the processor, and coordinates the activities of the other units. This unit also provides clock pulses. Clock pulses are used to regulate and control the speed of all the operations.

In addition to the ALU and CU (Control Unit), the processor has a number of storage locations to store information that is currently being processed. These are called *Registers*. These are temporary storage areas for instructions or data. Registers are managed by the control unit to accept, hold, and transfer instructions or data and perform arithmetic or logical comparisons at high speed.

2.3 System Bus

The CPU must be able to communicate with all devices. The devices are connected together by a communications channel called a **bus**. A bus is composed of a set of communication lines or wires. It is used to move large amount of bits in the form of electrical pulses from a specified source to a specified destination. The bus is used to connect the following units.

- Central Processing Unit
 - * Control Unit
 - * Arithmetic and Logic Unit
- Main memory (RAM , ROM)
- Input / Output Devices

Bus is the common path which is used to send /receive data and commands to / from CPU and memory and all input / output devices. It is also used to send / receive data from secondary storage. The capacity of a bus depends upon the number of data lines it contains. Bus with 16 lines can carry 16-bits (2 Bytes) at a time where as bus with 32 lines can carry 32-bits (4 Bytes)at a time and so on. There are three different buses in the computer system.

- Data Bus
- Address Bus
- Control bus

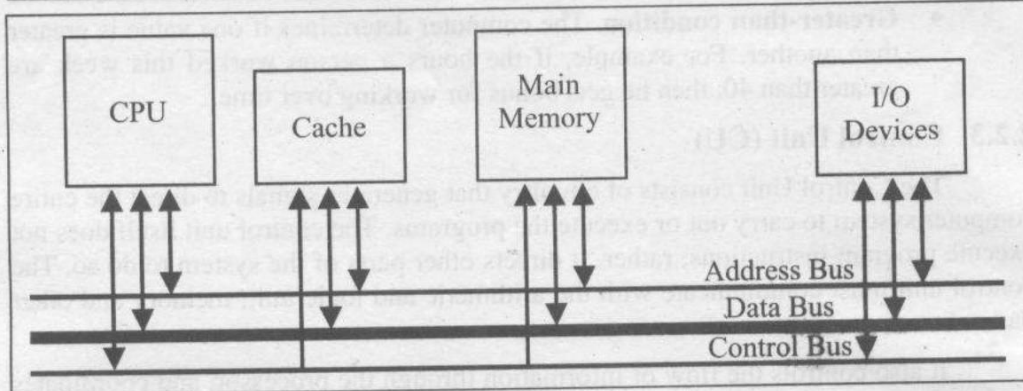

Figure 2.4: System Bus in a typical computer

2.3.1 Data Bus

The most common bus is the data bus. A data bus carries data. It is an electrical path that connects the central processing unit (CPU), memory, input / output devices and secondary storage devices. The bus contains parallel group of lines. The number of lines in the bus affects the speed at which the data travels between different components. Just like the number of lanes on a motorway affect the amount of traffic. Greater number of lanes on road means more cars can pass through it. If more lines are present in the bus, it can carry more data. e.g. a bus with 16 lines can carry 16 bits (2 bytes) and a bus with 32 lines can carry 32 bits (4 bytes) of data.

Busses are designed in such a way that they can communicate with the components in an efficient way. In old computers buses were able to carry only one byte of data but with the improvement in technology the busses present in today's computer can carry multiple bytes at one time thus improving the speed and performance of computers.

2.3.2 Address Bus

An address bus carries address information. It is a set of wires similar to the data bus but it only connects central processing unit (CPU) and memory. Whenever the processor needs data from the memory, it places the address of data on the address bus. The address is carried to the memory where the data from the requested address is fetched and placed on the data bus. The data bus carries it to the processor.

The reason for the importance of address bus is that the number of lines in the address bus determines the maximum number of memory addresses. If an address bus has 8 lines, the maximum number of memory locations that can be addressed are $2^8 = 256$. Today's computers have 32 bit address lines so they can access 4GB (Giga Byte) of memory.

2.3.3 Control Bus

The control bus carries control information from the control unit to the other units. The control information is used for directing the activities of all units. The control unit directs the transfer of data to the ALU from the memory. This data is used by ALU for processing. The control unit also controls the functioning of other units e.g. input/output devices, secondary storage etc.

2.4 Computer Storage

Computer storage is also referred to as **computer memory**. Computer memory is used to store programs and data. There are two types of computer memory.

- Main Storage or Main Memory
- Secondary Storage or Secondary Memory

Main memory is accessible directly by the processing unit. RAM is an example of main memory. As soon as the computer is switched off the contents of the main memory are lost. You can store and retrieve data much faster with main memory as compared to secondary memory. The reason is that the main memory is present on the mother board. Secondary memory such as floppy disks, magnetic disk, etc., is located outside the motherboard. Main memory is more expensive than secondary memory. That is why the size of main memory is less than that of secondary memory.

As the storage capacity of the main memory is limited and often it is necessary to store hundreds of millions of bytes of data for the CPU to process. Therefore, additional memory is required in all the computer systems. This memory is called **secondary memory or secondary storage**.

2.5 Input / Output Devices

A computer is only useful when it is able to communicate with the external environment. When we work with the computer, we feed data and instructions through some devices to the computer. These devices are called **input devices**. Similarly computer, after processing data and instructions, gives output through some devices called **output devices**. Input/output devices are also known as *peripheral devices*.

2.6 Ports

A **port** can be defined as a socket that enables an external device such as a printer to be attached to the computer". All communication between a computer and external devices is the result of properly connected ports. On every computer, a port's connectors are attached to a motherboard. There are three basic types of ports:

- Serial port
- Parallel port
- USB (Universal Serial Bus) port

Today's computers have all these types of ports with each type doing a different function (See Fig. 2.5, 2.6, 2.7).

2.6.1 Serial port

A serial port allows a serial hardware device to communicate with the computer by transmitting one bit of information at a time. Serial devices, such as mouse, modems, and keyboards, do not require fast data transmission rates. Serial ports often referred to as communications (COM) ports. It is an external port on the back of the computer that attaches directly to the PC's motherboard. These ports were one of the early ports put on computers. Older serial ports also used 25-pin connectors for their serial port, but most new computers with serial ports feature only nine pins.

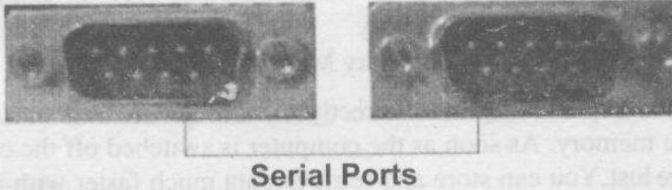

Figure 2.5 : Serial Ports

2.6.2 Parallel ports

A parallel port lets an external parallel device communicate with the computer by transmitting more bits (Such as 8 or 25) of data at a time therefore, it is much faster than a serial port. Most devices that send or receive large amounts of data, such as printers and scanners, use parallel ports. Parallel ports are often referred to as Line Printer (LPT) ports. The parallel port is the largest port on the rear of your PC, comprising 25 lines that include 17 signal lines and eight ground lines.

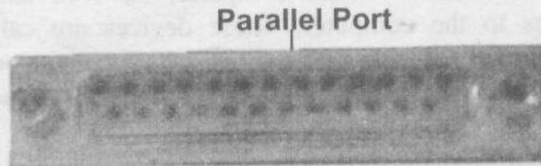

Figure 2.6 : Parallel Port

2.6.3 USB Ports

USB (Universal Serial Bus) is a plug-and-play hardware interface for peripherals such as the keyboard, mouse, joystick, scanner, printer and modem. USB has a maximum bandwidth of 12 Mbits/sec and up to 127 devices can be attached. With USB, a new device can be added to the computer without having to add an

adapter card. It typically is located at the back of the PC and looks as in the following Figure (sometimes positioned vertically). Sometimes it has the USB symbol next to it.

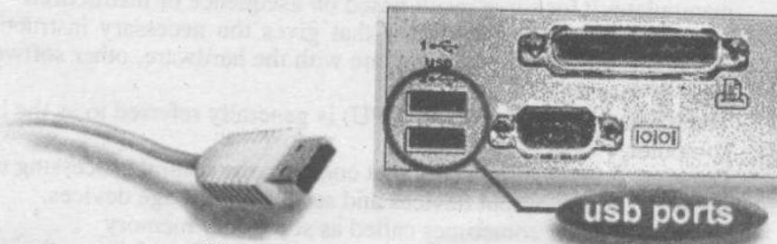

Figure 2.7: USB port and Connector

Exercise

1. What is the difference between computer hardware and software?
2. Write short notes on the following:
 - a. Central Processing Unit
 - b. Arithmetic and Logic Unit
 - c. Control Unit
3. What is a System Bus? Differentiate between data bus, address bus and control bus?
4. Differentiate between system software and application software?
5. Write a note on main memory and secondary memory? Also give examples.
6. What are the different kinds of input devices?
7. Define magnetic disk.
8. Explain Random access memory.
9. Fill in the blanks:
 - (i) The process of performing arithmetic and logic operations with the help of computer is known as _____.
 - (ii) Physical parts of the computer system that you can touch and feel are known as _____.
 - (iii) Most important part of the computer hardware is the _____.
 - (iv) An _____ is a set of programs that gives the necessary instructions to the computer, telling it how to operate with the hardware, other software and the user.
 - (v) The _____ and _____ unit contains the electronic circuitry that executes all arithmetic and logical operations.
 - (vi) The devices are connected together by a communications channel called a _____.
 - (vii) CPU is also called the _____ of the computer.
 - (viii) _____ is volatile memory.
 - (ix) Magnetic Tape is a _____ device.
 - (x) USB stands for _____.

10. Mark as True or false:

- (i) A computer is a device that accepts information in the form of data and manipulates it for some result based on a sequence of instructions
- (ii) An RAM is a set of programs that gives the necessary instructions to the computer, telling it how to operate with the hardware, other software and the user.
- (iii) The Central Processing Unit (CPU) is generally referred to as the brain of the computer.
- (iv) Data bus is an electrical path that connects the central processing unit (CPU), memory, input / output devices and secondary storage devices.
- (v) Main Memory is sometimes called as secondary memory
- (vi) The memories, which do not lose their content on failure of power supply, are known as **non-volatile** memories.
- (vii) A serial port allows a serial hardware device to communicate with the computer by transmitting one bit of information at a time.
- (viii) Address bus connects CPU, RAM and other I/O devices.
- (ix) Registers are high speed memory locations inside CPU
- (x) Instructions in ROM are used in booting process

11. Chose the correct option :

- (i) Which of the following devices is not inside the system unit ?
a. Random Access Memory (RAM) b. Monitor c. The Hard Disk
d. CD-ROM Drives e. The Modem
- (ii) Which of the following is a part of computer system?
a. Central Processing Unit b. Memory c. Input / Output Units
d. All of the above e. None of the above
- (iii) The arithmetic/logic unit can perform:
a. Addition b. Subtraction c. Multiplication d. All of the above
e. None of the above
- (iv) The system bus is used to connect the following units.
a. Central Processing Unit b. Main memory (RAM, ROM)
c. Input / Output Devices d. All of the above e. None of the above
- (v) Which of the following is not a type of bus in computer ?
a. Data Bus b. Address Bus c. Power Bus d. Control Bus e. All of the above

Answers

Q.9

- | | | |
|--------------------------------------|------------------------|---------------------------------------|
| (i) Electronic data processing (EDP) | (ii) Computer hardware | (iii) Central processing unit (CPU) |
| (iv) operating system (OS) | (v) Arithmetic, Logic | (vi) Bus |
| (vii) Brain | (viii) RAM | (ix) Storage (x) Universal Serial Bus |

Q.10

- | | | | | |
|--------|---------|----------|--------|-------|
| (i) T | (ii) F | (iii) T | (iv) T | (v) F |
| (vi) T | (vii) T | (viii) F | (ix) T | (x) T |

Q.11

- | | | | | |
|-------|--------|---------|--------|-------|
| (i) b | (ii) d | (iii) d | (iv) d | (v) c |
|-------|--------|---------|--------|-------|